

T90-1,5



Ratio
Rapporto / Verhältnis
1:1



RPM
Velocità / Drehzahl max.
8.000 min⁻¹



Max. axial load
Max. carico assiale / Max. Axialbelastung
250 N



Torque
Momento torcente / Drehmoment
15 Nm



Weight
Peso / Gewicht
4,3 kg



Collet
Pinza / Spannzange
ER-16 ø 1/10 mm

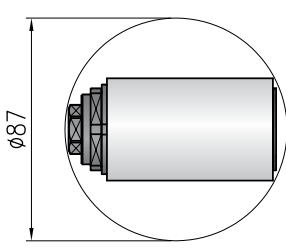
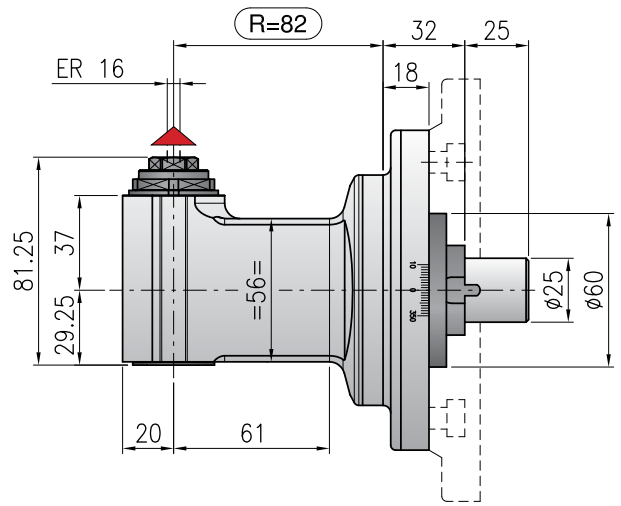

Minimum diameter without tool
Diametro minimo senza utensile
Durchmesser min. ohne Werkzeug

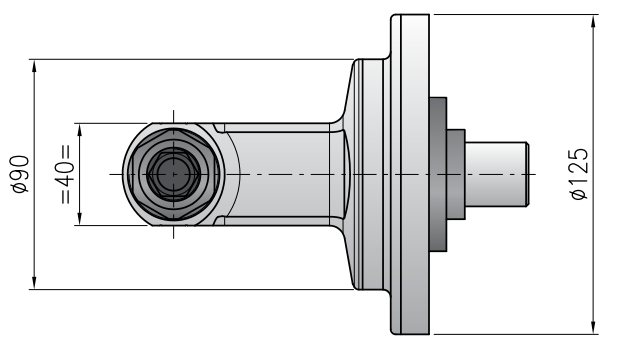

*** STANDARD EQUIPMENT INCLUDES:**

- Special bag - wrenches - Grease tube - Instruction book
- Bauletto - Ghiera ER chiavi di servizio - Tubetto di grasso - Libro istruzioni
- Spezialtasche - Schraubenschlüssel - Tube mit Fett - Bedienungsanleitung

▲ Direction of rotation opposite to machine spindle / senso di rotazione contrario al mandrino / Drehrichtung entgegen Antriebsspindel

Shank/ Cono/Aufnahme						
	DIN-69871	CAT	MAS-BT	HSK	CAPTO	KM

Option / Opzione / Option



bar max
12

Coolant through spindle
Addizione refrigerante interna
Kühlmittelzufuhr durch Spindel



min⁻¹
10.000

High speed optional RPM max.
Opzione alta velocità RPM max.
Drehzahl max.



Ø mm
13

Arbor output
Porta fresa
Fräseraufnahme



Ø mm max.
10

Weldon output
Weldon
Weldon-Aufnahme



ER-16/ER11

Double output
Doppia uscita
Doppelter Ausgang