

TR90cn-0,5

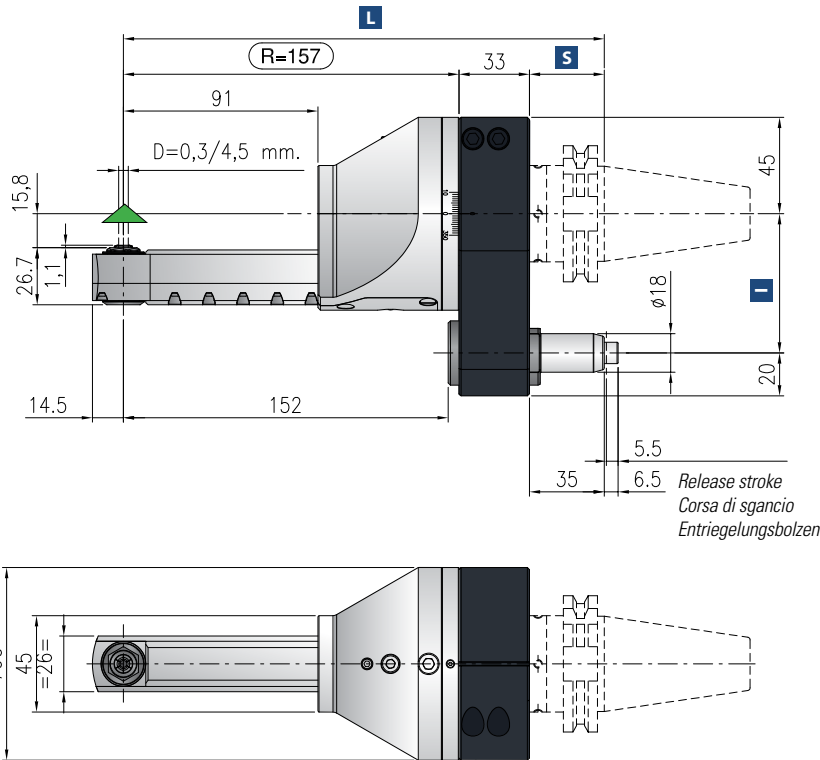

Minimum diameter without tool
 Diametro minimo senza utensile
 Durchmesser min. ohne Werkzeug

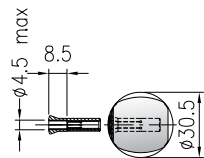

- Ratio
Rapporto / Verhältnis
2.375:1
- RPM
Velocità / Drehzahl max.
3.500 min⁻¹
- Max. axial load
Max. carico assiale / Max. Axialbelastung
135 N
- Torque
Momento torcente / Drehmoment
8 Nm
- Weight
Peso / Gewicht
4.5 kg
- Collet
Pinza / Spannzange
SCHAUBLIN P6

*** STANDARD EQUIPMENT INCLUDES:**

- Special bag - wrenches - Grease tube - Instruction book
- Bauletto - Ghiera ER chiavi di servizio - Tubetto di grasso - Libro istruzioni
- Spezialtasche - Schraubenschlüssel - Tube mit Fett - Bedienungsanleitung

Direction of rotation same as machine spindle / senso di rotazione uguale al mandrino / Drehrichtung gleich wie Antriebsspindel



Shank/Cono/Aufnahme	DIN-69871		CAT		MAS-BT		HSK		CAPTO		KM
Size/Grandezza/Größe	30	40	50	30	40	50	63-80	100	C5-C6	C8	50-63
I	65-80	65-80-(110*)	80-(110*)	65-80	65-80-(110*)	80-(110*)	65-80-(110*)	80-(110*)	65-80-(110*)	80-(110*)	65-80-(110*)
S	35	35	35	30	35	41	42	45	38	40	40
L	225	225	225	220	225	231	232	235	228	230	230

*optional

Non interchangeable input drive shank/ Coni di attacco non intercambiabili/ Nicht wechselbare Aufnahme

Option / Opzione / Option



bar max
12

Coolant through pin
 Adduzione refrigerante attraverso il perno
 Kühlmittelzufuhr durch Bolzen